

ASTM A403 WELDED FITTINGS

45° LONG RADIUS ELBOWS

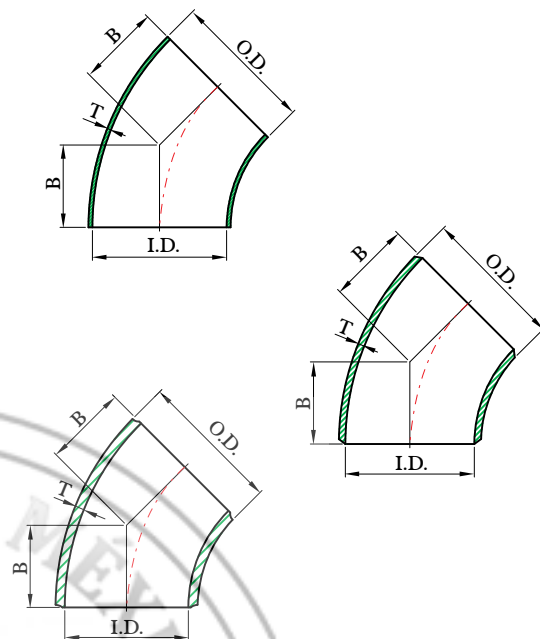

DIMENSIONS

unit : inch / lb

Nominal pipe size	Outside diameter (O.D.)	Center to face (B)	Schedule 5S			Schedule 10S			Schedule 40S		
			Inside diameter (I.D.)	Wall thickness (T)	Approx. weight * *	Inside diameter (I.D.)	Wall thickness (T)	Approx. weight * *	Inside diameter (I.D.)	Wall thickness (T)	Approx. weight * *
1/2	.840	5/8	.710	.065	.06	.674	.083	.07	.622	.109	.09
3/4	1.050	7/16	.920	.065	.06	.884	.083	.07	.824	.113	.09
1	1.315	7/8	1.185	.065	.12	1.097	.109	.19	1.049	.133	.25
1-1/4	1.660	1	1.530	.065	.19	1.442	.109	.25	1.380	.140	.38
1-1/2	1.900	1-1/8	1.770	.065	.25	1.682	.109	.38	1.610	.145	.50
2	2.375	1-3/8	2.245	.065	.31	2.157	.109	.56	2.067	.154	.88
2-1/2	2.875	1-3/4	2.709	.083	.75	2.635	.120	1.06	2.469	.203	1.69
3	3.500	2	3.334	.083	1.06	3.260	.120	1.38	3.068	.216	2.38
3-1/2	4.000	2-1/4	3.834	.083	1.16	3.760	.120	1.66	3.548	.226	3.13
4	4.500	2-1/2	4.334	.083	1.66	4.260	.120	2.38	4.026	.237	4.60
5	5.563	3-1/8	5.345	.109	3.25	5.295	.134	4.00	5.047	.258	7.57
6	6.625	3-3/4	6.407	.109	5.00	6.357	.134	6.00	6.065	.280	12.00
8	8.625	5	8.407	.109	8.65	8.329	.148	11.75	7.981	.322	23.75
10	10.750	6-1/4	10.482	.134	16.00	10.420	.165	21.50	10.020	.365	42.50
12	12.750	7-1/2	12.438	.156	25.50	12.390	.180	30.00	12.000	.375	65.50
14	14.000	8-3/4	13.688	.156	34.00	13.624	.188	40.00	13.250	.375	77.50
16	16.000	10	15.670	.165	50.00	15.624	.188	52.50	15.250	.375	101.00
18	18.000	11-1/4	17.670	.165	62.50	17.624	.188	66.00	17.250	.375	131.00
20	20.000	12-1/2	19.624	.188	82.50	19.564	.218	110.00	19.250	.375	165.00
24	24.000	15	23.564	.218	140.00	23.500	.250	155.00	23.250	.375	232.00



ASTM A403 WELDED FITTINGS

45° LONG RADIUS ELBOWS

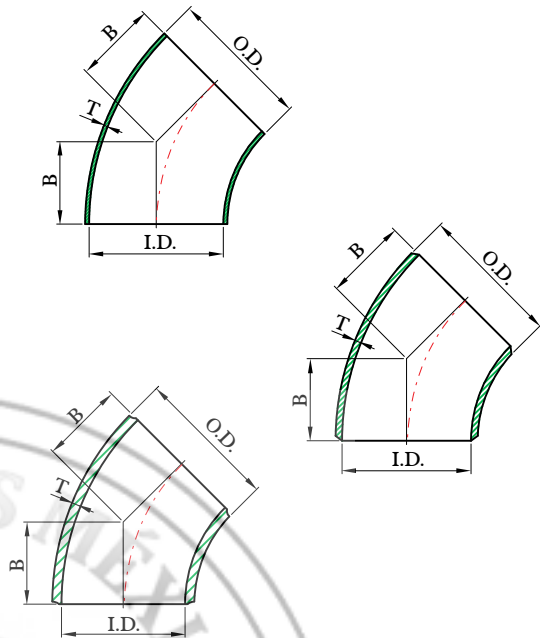

DIMENSIONS

unit : inch / lb

Nominal pipe size	Outside diameter (O.D.)	Center to face (B)	Schedule 80S			Schedule 160			XX Strong Wall		
			Inside diameter (I.D.)	Wall thickness (T)	Approx. weight * *	Inside diameter (I.D.)	Wall thickness (T)	Approx. weight * *	Inside diameter (I.D.)	Wall thickness (T)	Approx. weight * *
1/2	.840	5/8	.546	.147	.12	.464	.188	.16	.252	.294	.24
3/4	1.050	7/16	.742	.154	.12	.612	.219	.16	.434	.308	.24
1	1.315	7/8	.957	.179	.31	.815	.250	.43	.599	.358	.62
1-1/4	1.660	1	1.278	.191	.50	1.160	.250	.85	.896	.382	1.00
1-1/2	1.900	1-1/8	1.500	.200	.63	1.338	.281	.88	1.100	400	1.26
2	2.375	1-3/8	1.939	.218	1.13	1.689	.343	1.77	1.503	436	2.26
2-1/2	2.875	1-3/4	2.323	.276	2.19	2.125	.375	2.95	1.771	552	4.38
3	3.500	2	2.900	.300	3.31	2.624	.438	4.80	2.300	600	6.62
3-1/2	4.000	2-1/4	3.364	.318	4.40	-----	-----	-----	2.728	636	8.80
4	4.500	2-1/2	3.826	.337	6.82	3.438	.531	10.87	3.152	.674	13.64
5	5.563	3-1/8	4.813	.375	10.56	4.313	.625	17.52	4.063	.750	21.12
6	6.625	3-3/4	5.761	.432	18.00	5.187	.719	20.88	4.897	.864	36.00
8	8.625	5	7.625	.500	36.50	6.813	.906	64.24	6.875	.875	63.87
10	10.750	6-1/4	9.750	.500	57.00	8.500	1.125	127.00	-----	-----	-----
12	12.750	7-1/2	11.750	.500	87.50	10.126	1.312	229.00	-----	-----	-----
14	14.000	8-3/4	13.000	.500	103.00	11.188	1.406	-----	-----	-----	-----
16	16.000	10	15.000	.500	134.00	12.812	1.594	-----	-----	-----	-----
18	18.000	11-1/4	17.000	.500	175.00	14.438	1.781	-----	-----	-----	-----
20	20.000	12-1/2	19.000	.500	219.00	16.062	1.969	-----	-----	-----	-----
24	24.000	15	23.000	.500	308.00	19.312	2.344	-----	-----	-----	-----