

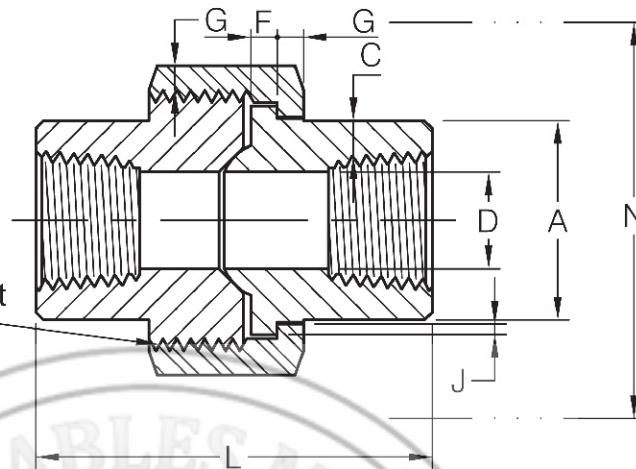

THREADED END UNION

MSS SP-83-2006

H-Thrd's
Minimum 4 Full Thrd's
Engagement Class 2A/2B Fit
ANSI B1.1



3000Lb

Dimensions in Millimeters.

Nom. Pipe Size	Pipe End (Min) A	Wall (Min) C	Water Way Bore D ⁽¹⁾	Male Flange (Min) F	Nut (Min) G	Thrds. Per 25.4mm H	Bearing (Min) J	Length Assem. Nom. L	Clear Assem. Nut N
1/8	14.7	2.41	8.43 6.43	3.18	3.18	16	1.24	41.4	50.8
1/4	19.0	3.02	11.13 9.45	3.18	3.18	16	1.24	41.4	50.8
3/8	22.9	3.20	14.27 13.51	3.43	3.43	14	1.37	46.0	55.9
1/2	27.7	3.73	17.86 17.07	3.68	3.68	14	1.50	49.0	58.4
3/4	33.5	3.91	23.01 21.39	4.06	4.06	11	1.68	56.9	66.0
1	41.4	4.55	28.98 27.74	4.57	4.45	11	1.85	62.0	78.7
1-1/4	50.5	4.85	37.69 35.36	5.33	5.21	10	2.13	71.1	94.0
1-1/2	57.2	5.08	43.54 41.20	5.84	5.59	10	2.31	76.5	111.8
2	70.1	5.54	55.58 52.12	6.60	6.35	10	2.69	86.1	132.1
2-1/2	85.3	7.01	66.27 64.31	7.49	7.11	8	3.07	102.4	149.9
3	102.4	7.62	88.25 77.27	8.26	8.00	8	3.53	109.0	175.3

(1) Upper and lower values for each size are the respective maximum and minimum dimensions.



SOCKET WELD END UNION

MSS SP-83-2006

H-Thrd's
Minimum 4 Full Thrd's
Engagement Class 2A/2B Fit
ANSI B1.1

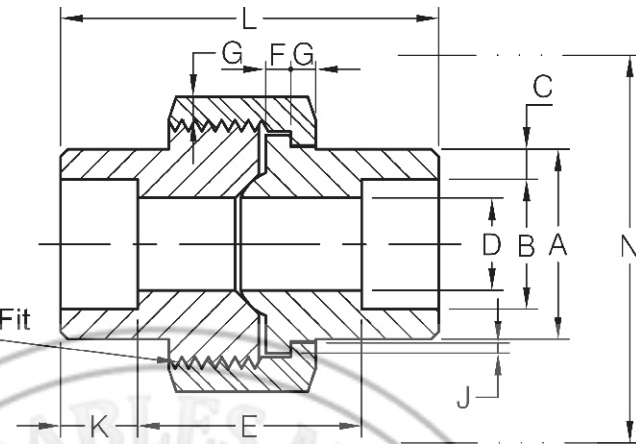

3000Lb

Dimensions in Millimeters.

Nom. Pipe Size	Pipe End (Min) A	Socket Bore Dia. B ⁽¹⁾	Socket Wall (Min) C	Water Way Bore D ⁽¹⁾	Laying Length E ⁽¹⁾	Male Flange (Min) F	Nut (Min) G	Thrds. Per 25.4mm H	Bearing (Min) J	Depth of Socket (Min) K	Length Assem. Nom. L	Clear Assem. Nut N
1/8	21.8	11.18 10.67	3.18	7.59 6.07	22.4 19.1	3.18	3.18	16	1.24	9.7	41.4	50.8
1/4	21.8	14.61 14.10	3.30	10.01 8.48	22.4 19.1	3.18	3.18	16	1.24	9.7	41.4	50.8
3/8	25.9	18.03 17.53	3.51	13.28 11.76	26.9 20.6	3.43	3.43	14	1.37	9.7	46.0	55.9
1/2	31.2	22.23 21.72	4.09	16.56 15.04	26.9 20.6	3.68	3.68	14	1.50	9.7	49.0	58.4
3/4	37.1	27.56 27.05	4.27	21.69 20.17	31.8 25.4	4.06	4.06	11	1.68	12.7	56.9	66.0
1	45.5	34.29 33.78	4.98	27.41 25.88	34.3 26.2	4.57	4.45	11	1.85	12.7	62.0	78.7
1-1/4	54.9	43.05 42.55	5.28	35.81 34.29	40.6 32.5	5.33	5.21	10	2.13	12.7	71.1	94.0
1-1/2	61.5	49.15 48.64	5.54	41.66 40.13	42.2 34.0	5.84	5.59	10	2.31	12.7	76.5	111.8
2	75.2	61.62 61.11	6.05	53.26 51.74	45.5 37.3	6.60	6.35	10	2.69	15.7	86.1	132.1
2-1/2	91.7	74.45 73.81	7.67	64.24 61.19	61.7 52.1	7.49	7.11	8	3.07	15.7	102.4	149.9
3	109.2	90.42 89.79	8.31	79.45 76.40	63.8 53.6	8.26	8.00	8	3.53	15.7	109.0	175.3

(1) Upper and lower values for each size are the respective maximum and minimum dimensions.