

DESIGN FEATURES

- Blow-out Proof Stem
- Pressure Balance Hole in Ball Slot
- Various Thread Standards Available
- NACE MR-0175 (Optional)
- Casting Approved by TÜV AD 2000-Merkblatt W0

APPLICABLE STANDARDS

- Design Standard : MSS SP-110
- Wall Thickness : EN12516-3,
- Pipe Thread (KV-030) : ASME B1.20.1, BS21
DIN 2999/259, ISO 228/1
JIS B0203 ISO7/1
- Butt Weld (KV-031,031-L) : ASME B16.25(Ø B2 Sch40) , EN 12627
- Socket Weld (KV-032) : ASME B16.11
- Inspection & Testing : MSS SP-110



CV VALUES

NPS	DN	CV
1/4	8	10
3/8	10	13
1/2	15	18
3/4	20	36
1	25	48
1 1/4	32	93
1 1/2	40	165
2	50	207
2 1/2	65	450
3	80	780

WEIGHT

NPS	DN	KV-030		KV-031		KV-032		KV-031-L	
		(kg)	(lb)	(kg)	(lb)	(kg)	(lb)	(kg)	(lb)
1/4	8	0.49	1.08	0.44	0.97	0.46	1.01	0.44	0.97
3/8	10	0.45	0.99	0.43	0.95	0.50	1.10	0.43	0.95
1/2	15	0.49	1.08	0.48	1.06	0.63	1.39	0.48	1.06
3/4	20	0.77	1.70	0.79	1.75	0.76	1.68	0.79	1.75
1	25	1.21	2.67	1.17	2.58	1.18	2.60	1.17	2.58
1 1/4	32	1.86	4.10	1.88	4.14	1.84	4.06	1.88	4.14
1 1/2	40	2.63	5.80	2.68	5.91	2.65	5.84	2.68	5.91
2	50	4.15	9.15	4.00	8.82	3.82	8.42	4.00	8.82
2 1/2	65	8.25	18.19	8.00	17.64	8.08	17.81	8.00	17.64
3	80	11.5	25.35	11.8	26.01	10.7	23.50	11.8	26.01

TORQUE VALUES

Close to Open Torque at Various Differential Pressure (ΔP), Standard Seats (TFM1600 & PTFE)

unit : in-lb / N-m

Size ΔP		75psig		150psig		300psig		700psig		1000psig	
		5bar		10bar		20bar		50bar		63bar	
NPS	DN	N-m	In-lb	N-m	In-lb	N-m	In-lb	N-m	In-lb	N-m	In-lb
1/4	8	4.5	40	4.5	40	4.5	40	4.5	40	4.5	40
3/8	10	4.5	40	4.5	40	4.5	40	4.5	40	4.5	40
1/2	15	5	44	5	44	5	44	5	44	5	44
3/4	20	6	53	6	53	6	53	6	53	6	53
1	25	10	88	10	89	11	97	11	97	11	97
1 1/4	32	13	115	13	115	15	133	17	150	19	168
1 1/2	40	19	168	19	168	22	195	24	212	26	230
2	50	25	221	29	257	32	283	35	310	38	336
2 1/2	65	40	354	45	398	49	434	54	478	59	522
3	80	65	575	72	637	81	717	90	796	101	894

- Remark :
1. Torques will increase about 30% if seat materials are Reinforced Fiber-Glass PTFE, Carbon-filled PTFE or EK+PTFE or TFM4215.
 2. The torque figures at 5 bar pressure are maximum values to be tested after the valves are placed for 24 hours.
 3. For actuator sizing, a safety factor of minimum 30% is recommended.

TECHNICAL INFORMATION

TEL. (55)5369-1902

(55)5367-5890

PRESSURE - TEMPERATURE DATA

The pressure-temperature data of ball valves is determined not only by valve shell materials but also by sealing materials used for ball seats, gland packings and flange gaskets.

Full Bore : NPS 1/2 ~ NPS 1 1/4
DN15 to DN32

Full Bore : NPS 1 1/2 ~ NPS 3
DN40 to DN80

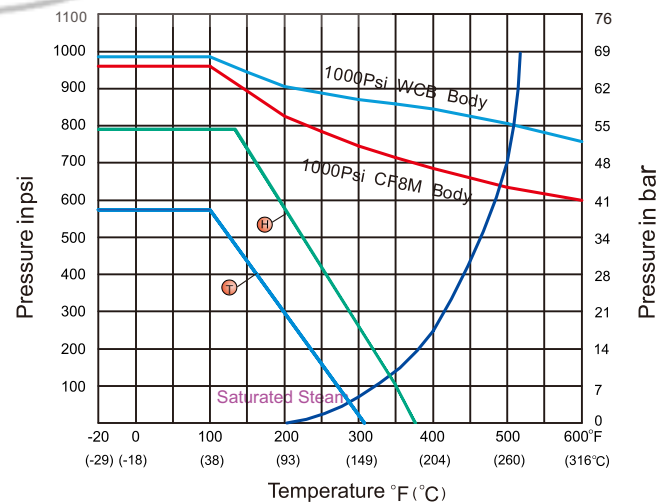
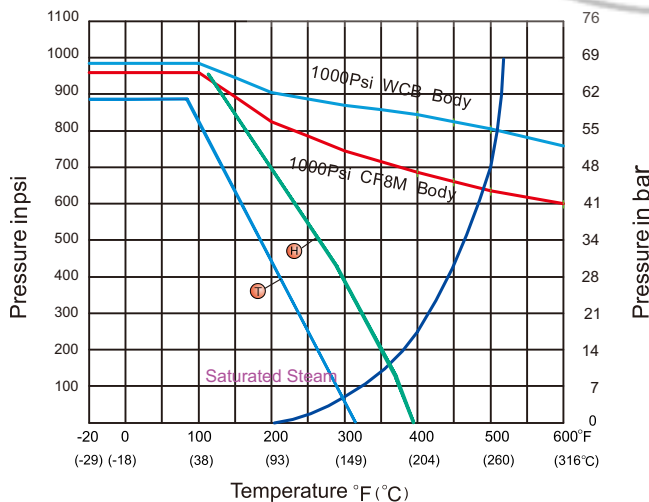

Seat Materials : T PTFE H TFM1600

Body Ratings: Shown above are for ASTM A351 Gr.CF8M and A216 Gr.WCB

For ratings of other valve shell materials, please refer to the last edition of ASME B16.34.

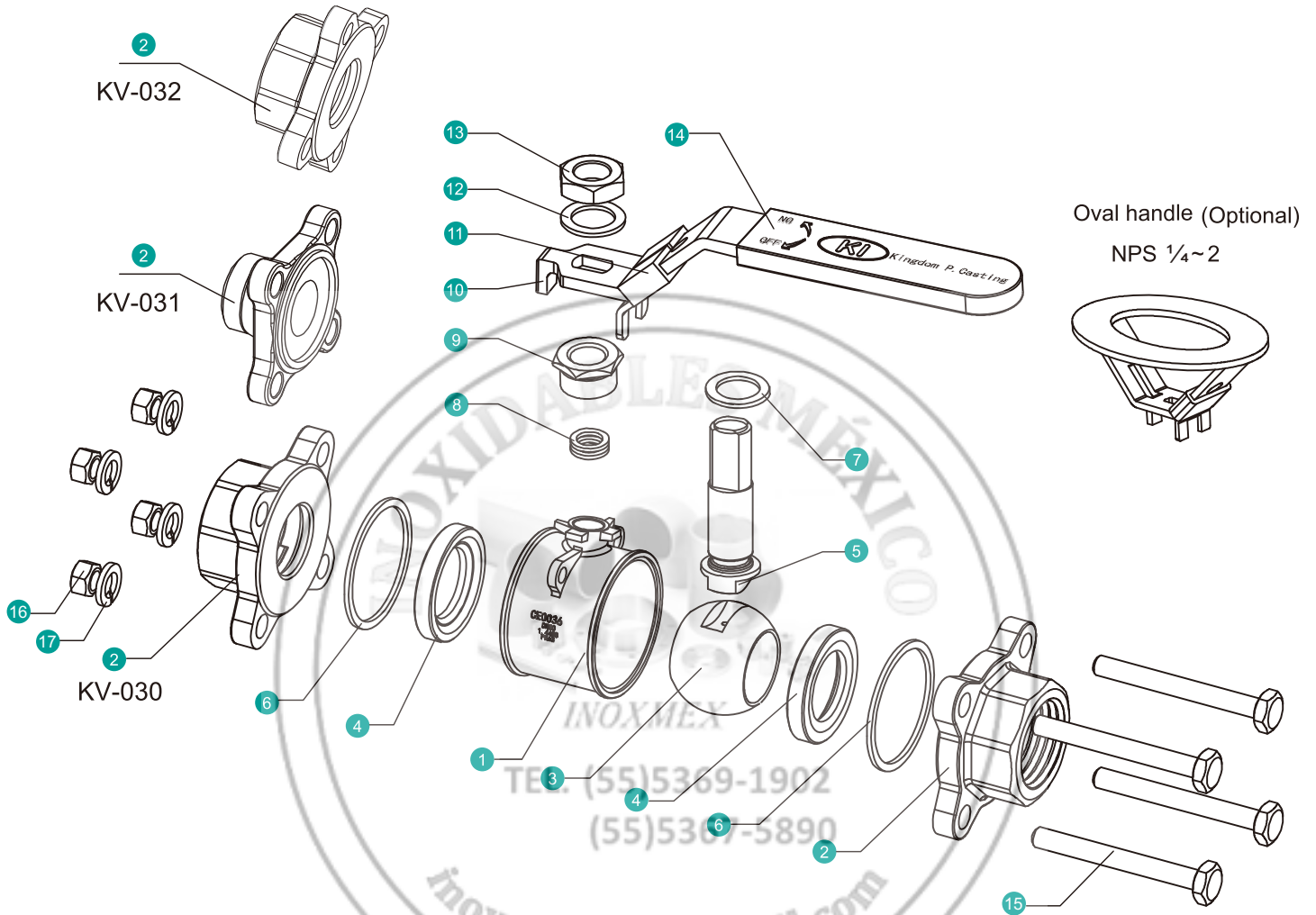

MATERIAL OF CONSTRUCTION

NO.	PART NAME	MATERIALS		
1	Body	CF8M(1.4408)	CF8(1.4308)	WCB(1.0619)
2	End Cap(Thread)	CF8M(1.4408)	CF8(1.4308)	WCB(1.0619)
	End Cap(BW/SW)	CF3M(1.4409)	CF8(1.4308)	WCB(1.0619)
3	Ball	CF8M	CF8	
4	Ball Seat	TFM1600/ PTFE		
5	Stem	316	304	
6	Body Gasket	PTFE / TFM1600		
7	Thrust washer	PTFE / TFM1600		
8	Packing	PTFE / GRAPHITE		
9	Gland Nut	304		
10	Handle	304		
11	Lock Device	304		
12	Stem Washer	304		
13	Handle Nut	A194-8		
14	Handle Sleeve	VINYL PLASTIC		
15	Bolting	A193-B8/A2-70		
16	Bolt Nut	A194-8/A2-70		
17	Bolt Washer	304		

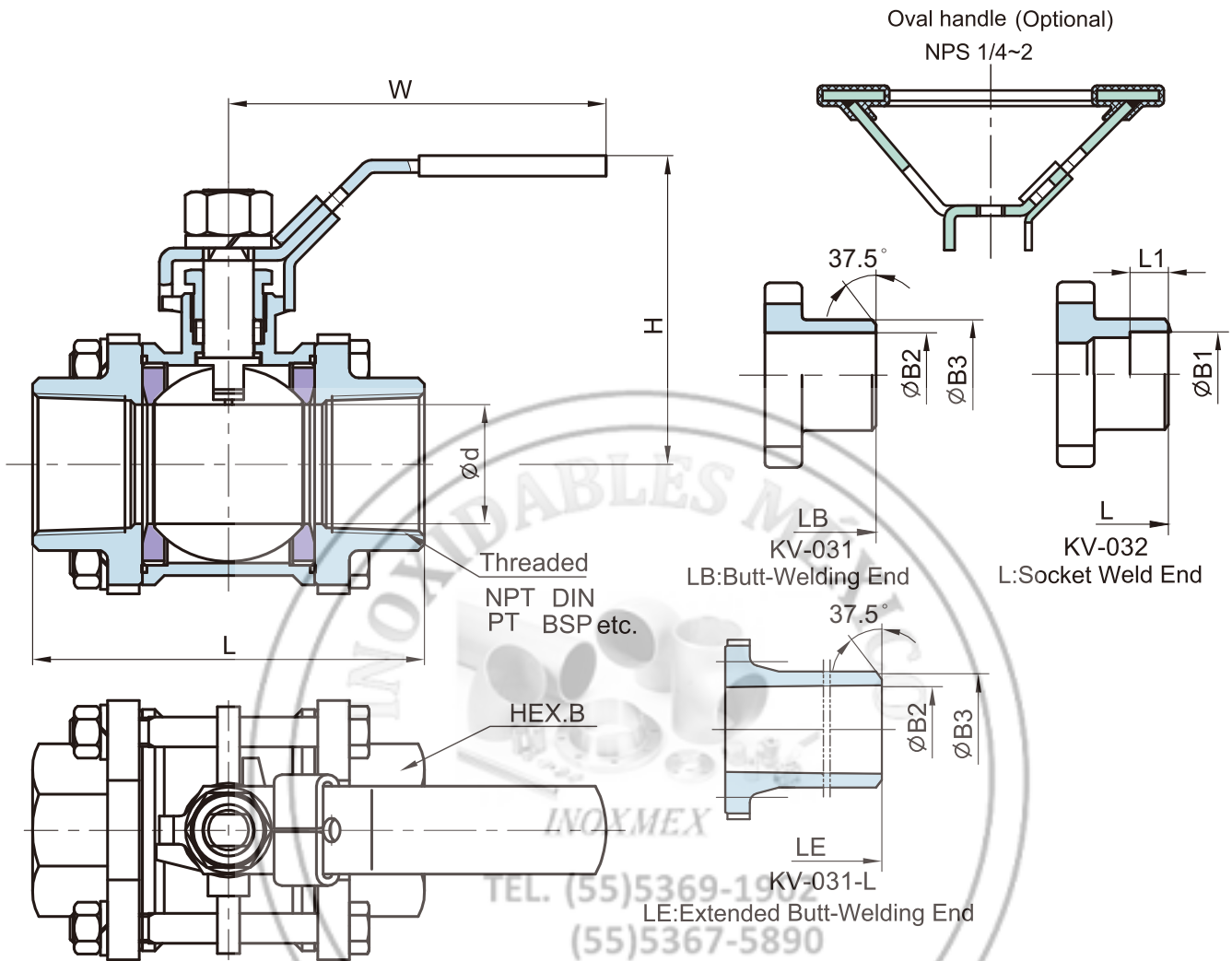

DIMENSION TABLE

ANSI 1000 WOG DIMENSION TABLE

Unit : mm

NPS	DN	d	L	LB	LE	H	W	B1	B2	B3	L1	HEX.B
1/4	8	10.6	65.2	65.2	225	58	100	14.2	9.3	18	10.0	22
3/8	10	12.7	65.2	65.2	225	58	100	17.8	12.5	18	10.0	23.5
1/2	15	15	69.5	75	225	58	100	21.8	15.8	22	10.0	28
3/4	20	20	80	90	225	63	129	27.3	20.9	28	13.0	34.5
1	25	25	90	100	245	76	156	34.0	26.7	34	13.0	42
1 1/4	32	32	110	110	255	81	156	42.8	35.1	43	16.0	52
1 1/2	40	38	120	125	260	94	184	48.9	40.9	50	16.0	58.5
2	50	50	140	150	275	105	184	61.4	52.5	61	17.0	71.5
2 1/2	65	63.5	185	190	330	131	252	74.0	62.7	76	17.0	86.5
3	80	76	205	220	356	139	252	90.0	78.0	92	17.0	101

ANSI 1000 WOG DIMENSION TABLE

Unit : inch

NPS	DN	d	L	LB	LE	H	W	B1	B2	B3	L1	HEX.B
1/4	8	0.42	2.57	2.57	8.86	2.26	3.94	0.56	0.37	0.71	0.39	0.87
3/8	10	0.50	2.57	2.57	8.86	2.26	3.94	0.70	0.49	0.71	0.39	0.93
1/2	15	0.59	2.74	2.95	8.86	2.26	3.94	0.86	0.62	0.87	0.39	1.10
3/4	20	0.79	3.15	3.54	8.86	2.48	5.08	1.07	0.82	1.10	0.51	1.36
1	25	0.98	3.54	3.94	9.65	2.97	6.14	1.34	1.05	1.34	0.51	1.65
1 1/4	32	1.26	4.33	4.33	10.04	3.19	6.14	1.69	1.38	1.69	0.63	2.05
1 1/2	40	1.50	4.72	4.92	10.24	3.70	7.24	1.93	1.61	1.97	0.63	2.30
2	50	1.97	5.51	5.91	10.83	4.11	7.24	2.42	2.07	2.40	0.67	2.81
2 1/2	65	2.50	7.28	7.48	12.99	5.16	9.92	2.91	2.47	2.99	0.67	3.41
3	80	2.99	8.07	8.66	14.02	5.47	9.92	3.54	3.07	3.62	0.67	3.98

*For valves with butt weld ends per DIN11850 series 2 or ISO1127, the pressure rating will be 400 WOG.